

OPERATION AND PARTS MANUAL

DH0612 11G24 Simple Saw System

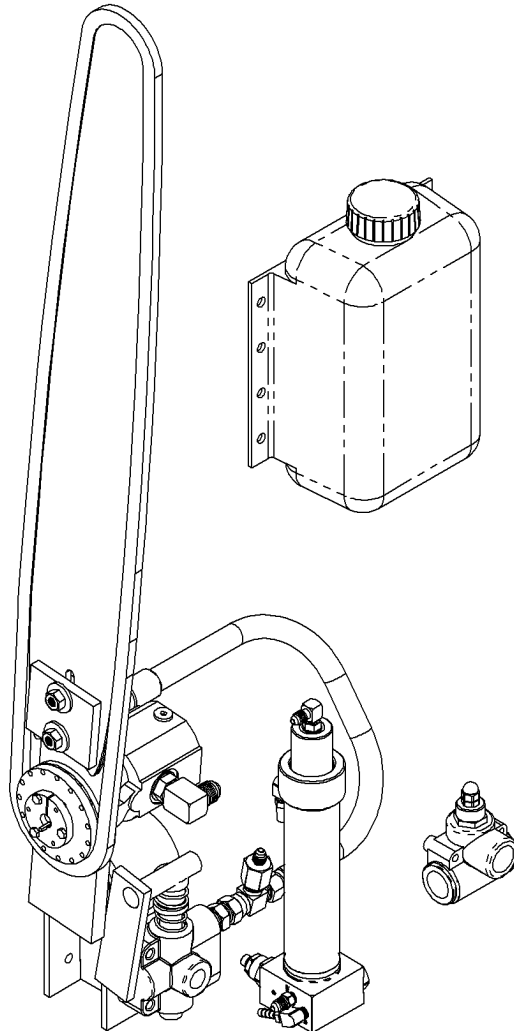

6KProducts

Bringing reliability to high pressure hydraulic systems

1006 143rd Ave S.E. Phone (360) 264-2141

Tenino, WA 98589 Fax (360) 264-5105

www.6kproducts.com

Information subject to change without notice.

SAFETY PRECAUTIONS

- ⇒ **The unit you have purchased may require you to install additional guarding to meet State and Federal safety requirements.**
- ⇒ **Do not move the log when it is being cut or when the saw is down. This action may damage the bar, chain or other components or could cause bodily harm or injury.**
- ⇒ **The log must be clamped before cutting. The bar, chain or other components could be damaged. You could suffer bodily harm or injury.**
- ⇒ **Do not make repairs or adjustments to this product other than those listed in this manual except when directed to do so by 6K Products.**
- ⇒ **All persons working near this machine must wear eye protection and hearing protection.**
- ⇒ **Use extreme caution around the cutting chain. It is sharp and may cause bodily harm or injury.**
- ⇒ **Petroleum products are used with this product. Use appropriate caution when operating or servicing. These products are flammable and may cause eye or skin irritation.**
- ⇒ **Always use 6K Products approved parts when making repairs. Replacement parts must meet or exceed the specifications of the original equipment manufacturer.**
- ⇒ **The information in this manual is subject to change without notification.**
- ⇒ **This manual is intended for safe operation and maintenance of the 6K Products, 11G24 Simple Saw System. 6K Products, welcomes any and all suggestions on how to improve this manual or the 11G24 Simple Saw System.**

Table of Contents

- Cover page** 1
- Safety Precaution 2
- Table of Contents 3
- Introduction 4
- Warranty 4
- Installation 4
- Hydraulic Connections 6
- Chain Tension and Sharpening 7
- Sprocket Removal and Replacement 8
- Bar Oil Pump Adjustment 9
- Operating Instruction 10
- Parts and Service Information 10
- Main Sub Assembly Parts 11
- Simple Saw Assembly Parts 12
- Bar Oil Pump Assembly Parts 13
- Bar Oil Tank Assembly Parts 14

Introduction

Thank you for purchasing a 6K Products product. Our goal is to provide quality products for your job. This manual contains warranty information, installation information, operation instructions, parts ordering information, and service contact information.

Warranty

This 6K Products product carries a one year or 2000 hour warranty on the 6K Products designed and built components covering material and workmanship. Purchased components carry the manufactures warranty. This warranty does not cover normal wear from use, damage from abuse or misuse, damage from contamination, damage from natural disasters, fire damage or incorrect installation. This warranty does not cover labor to remove and replace parts, shipping and handling of parts, or shipping and handling for items returned for repair. If any component fails you must contact 6K Products at (360)264-2141 before doing any repair work. We will provide assistance to obtain warranty from other manufactures on their components.

Installation

You will receive one box containing all the parts (Fig. 1). You will need to reassembly the saw unit as shown in figure 2.

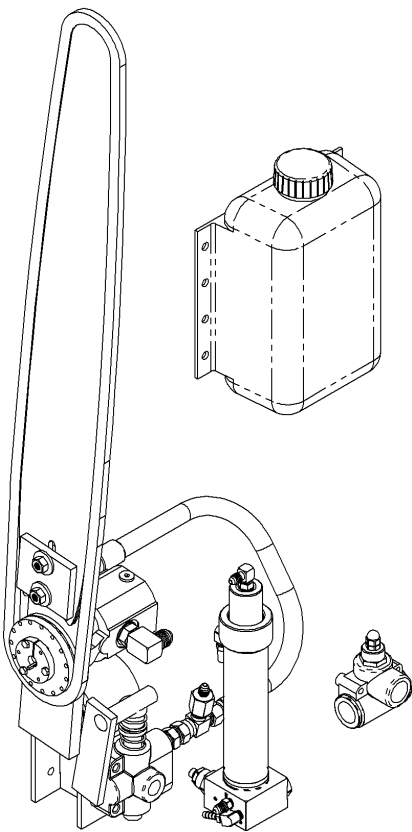

Fig. 1

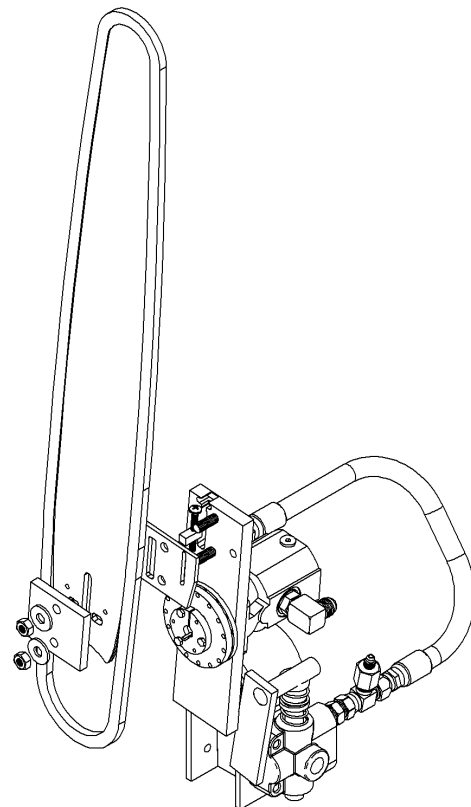

Fig. 2

6KProducts

Bringing reliability to high pressure hydraulic systems

After assembling the components as shown in figure 2, position the saw bar square to the log, at the correct height with clearance between the bar plate and the side of the largest log and weld down solidly (Fig. 3). The dimensions in figure 3 can be changed as required for your installation. Position the bar oil pump above the bar plate port when retracted, and below the bar oil tank with the bar oil tank positioned so it is easy to clean and fill. You will need to fabricate and position a lever to feed the saw through the cut and return it to the retracted position. You will need to make guarding to protect the operator from sawdust and touching the chain.

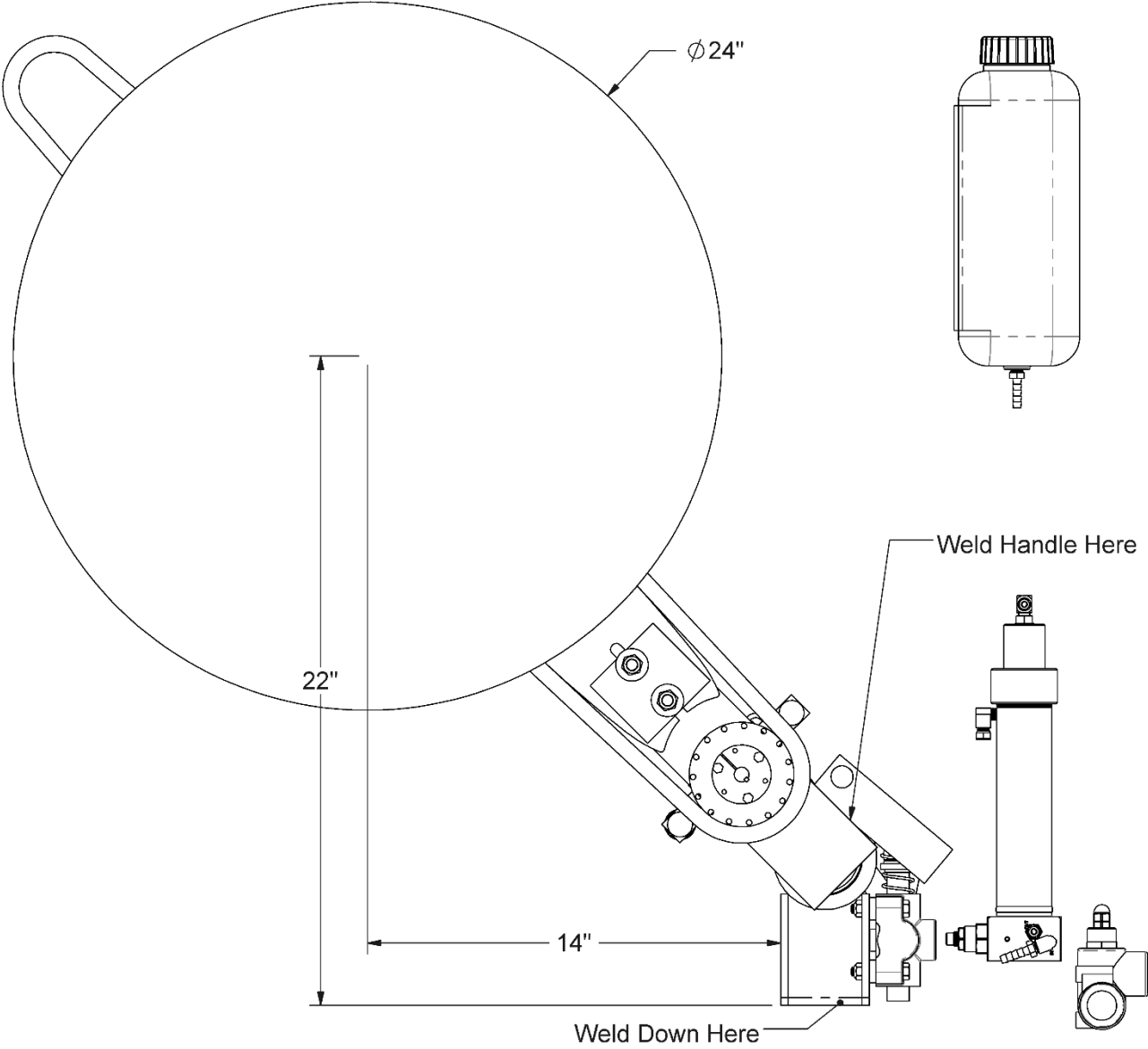

Fig. 3

Hydraulic Connections

The hydraulic requirements to operate the saw are 10 to 12 gallons per minute at 2000 psi from a fixed displacement hydraulic pump. You must install the pressure relief valve between the hydraulic pump and the selector valve to keep from damaging the hydraulic pump. Figure 4 shows hose connections for correct operation.

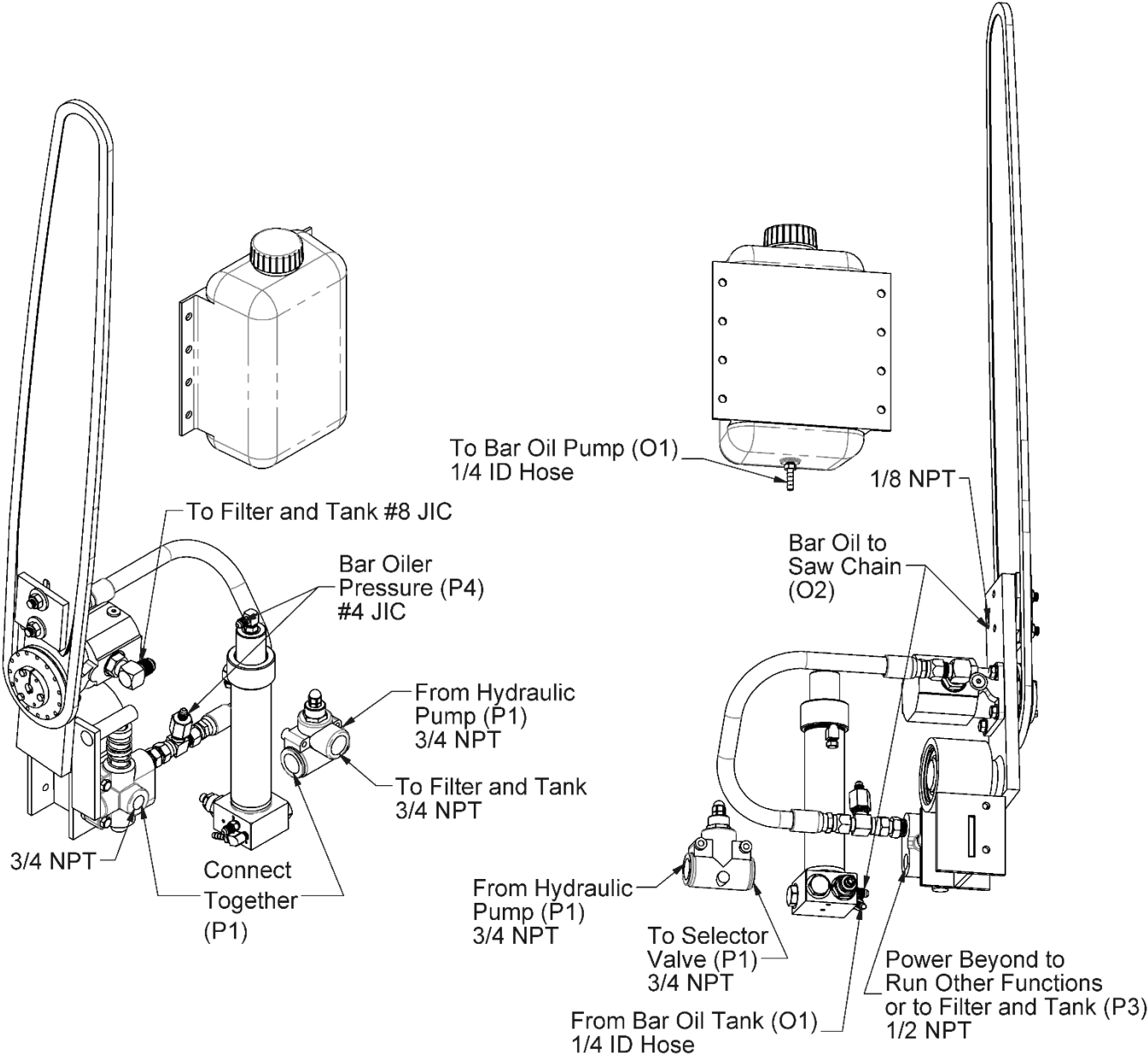

Fig. 4

The Power Beyond Port can connect to another valve for conveyor and clamp, or must go to the filter and tank. The return hose can be #8 or 1/2" diameter for the first five feet. If a longer hose is required it must be #12 or 3/4" up to thirty feet. If the total return hose length is greater than thirty three feet #16 or 1" hose should be used. The filter must be rated for 15 GPM plus any additional pump flowing into it. The saw motor should run between 4000 RPM and 5500 RPM. At this speed the pressure at the return to filter connection should not exceed 80 psi when the saw motor is running. We do not recommend using quick disconnects but if you choose to use quick disconnects in the tank line, first consult the manufacture to determine the correct size to keep the back pressure low enough in cold temperatures. Failure to properly size the hose and filter or properly connect the return hose to a filter and tank will shorten the motor shaft seal life and will not be covered by warranty.

Chain Tension and Sharpening

Figure 5 shows the chain tensioning screw. A #2 or #3 Phillips screwdriver is required to turn the tension screw. With the supplied saw bar, correct tension is when the cutters come off the rails roughly 1/8" with a tug of finger pressure. Refer to the Oregon Mechanical Timber Harvesting Handbook for more tensioning information and sharpening information.

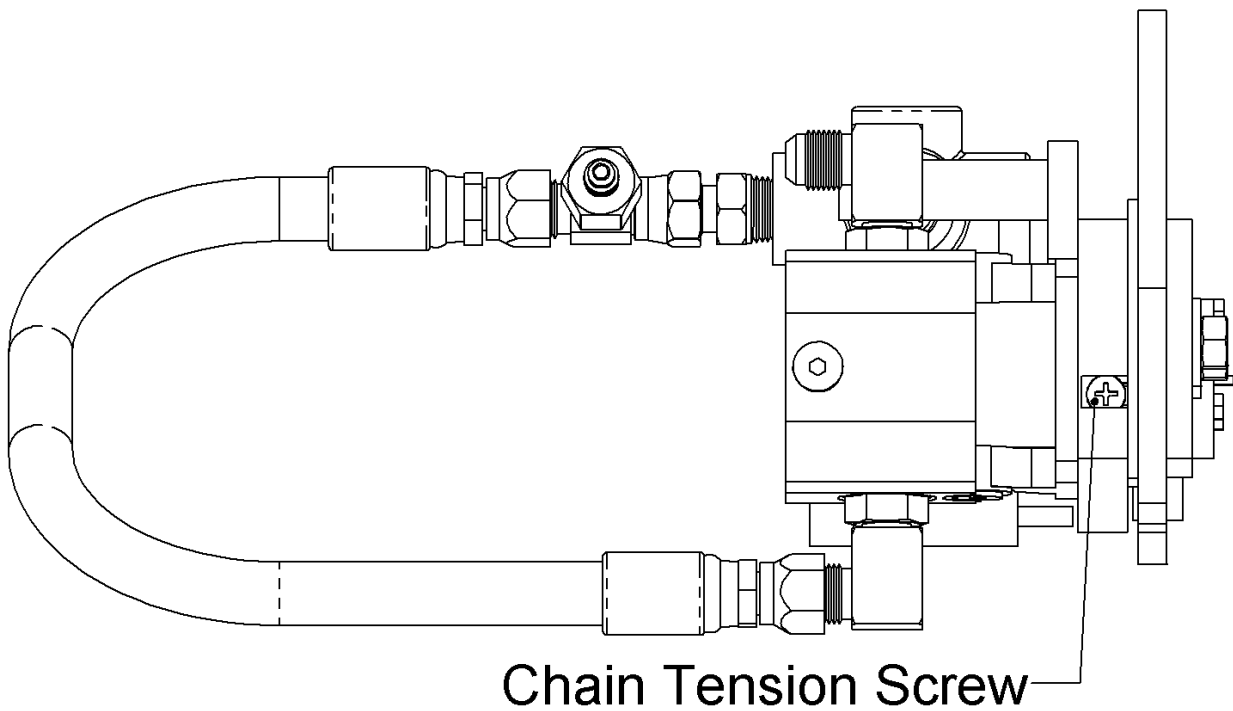

Fig. 5

Sprocket Removal and Replacement

The chain saw sprocket is connected to the shaft with a tapered bushing. To remove the sprocket remove the Cap Screws (Fig. 6, Item 3) and screw them into the Threaded Holes, tighten up to 36 inch pounds to push the Sprocket (Fig. 6, Item 1) off the Bushing (Fig. 6, Item 2). You may need to tap the Sprocket towards the motor with a hammer to assist in getting the Sprocket loose from the Bushing. Lightly drive a flat blade screwdriver into the slot of the Bushing.

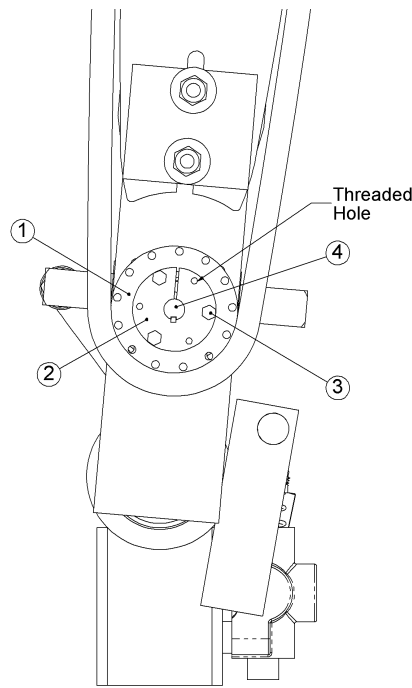

Fig. 6

Pry between the Bushing and the Sprocket to get the Bushing off the shaft. Watch that the Drive Key (Fig. 6, item 4) does not get lost.

To install the Sprocket, slide the Sprocket (Fig. 6, item 1) over the motor shaft, slide the Bushing (Fig. 6, item 2) onto the shaft with the Drive Key (Fig. 6, item 4) aligned. Position the sprocket groove offset towards the motor about the width of the bar groove with the Bushing just contacting the Sprocket. Insert the Cap Screws (Fig. 6, item 3) through the large hole in the Bushing and screw them into the threaded holes of the Sprocket. Torque the Cap Screws (Fig. 6, item 3) to 36 inch pounds. Check to make sure the sprocket groove is aligned with the bar groove. If the alignment is not correct, remove and replace the sprocket and bushing and adjust the position before tightening the cap screws.

Bar Oil Pump Adjustments

The DH0144 bar oil pump (Fig. 7) is a single acting pump that can pump up to 32 cc, or 1.08 oz., of bar oil per cycle, enough for about 30 seconds of cutting. There is a hose connected to the selector valve manifold (Fig. 4, P4 page 6) that connects to the fitting (Fig. 7, hydraulic pressure in) on the bar oil pump. When a cut is started flow and pressure from the manifold pushes on the pumping rod and piston to force a metered amount of oil to the bar. Very little rotational adjustment is needed for the metering valve in Figure 7. Turning it clockwise reduces the speed oil is pumped and turning it counterclockwise increases the speed the oil comes out. If you run the tank out of oil you may need to prime the pump. To prime the pump remove the barrel nut and pull out the pumping chamber, pumping piston, and pumping rod. Fill the barrel with bar oil up to the vent hole. Reinstall the pumping rod assembly into the pumping chamber with care to not damage the rod seal. Reinstall the pumping chamber and pumping rod assembly into the barrel, with care to not damage the piston or the O-Ring, and retighten the barrel nut. To reduce the chance of seal damage make sure the seals are oiled and wiggle in a circular motion as you push the parts together.

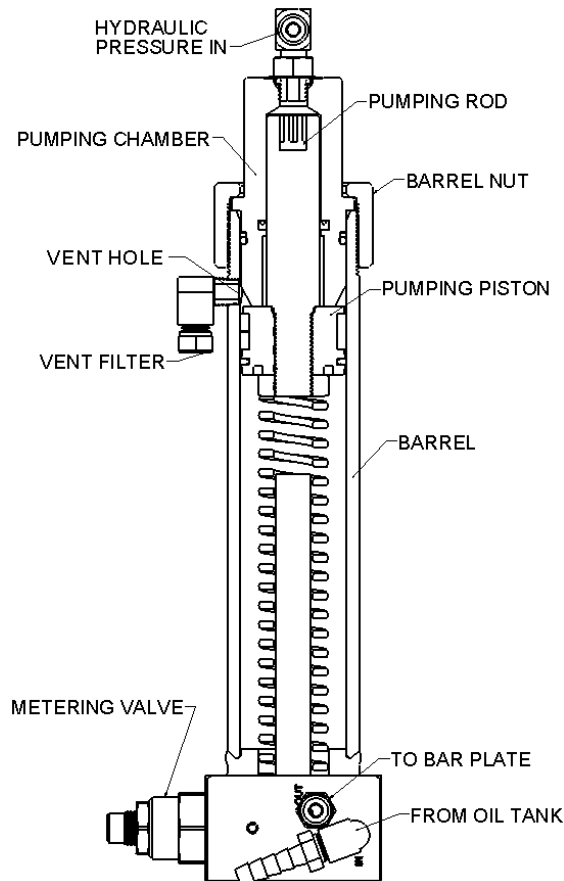

Fig. 7

Operating Instructions

Before, and periodically during, operation you must check the bar oil level and chain tension. We recommend using a good quality bar oil of the correct viscosity for your areas operating temperatures. Because of the wide temperature range between winter and summer two different viscosity oils may be required. Tension the chain as described on page 7. The log being cut must be clamped prior to sawing. Lowering the saw bar will allow the selector valve to shift starting the saw chain and pumping bar oil. Returning the saw to the up stop will stop the saw chain and reset the bar oil pump.

Parts and Service Information

For parts and service contact 6K Products. Our hours of operation are 8:00 AM to 4:30 PM, Monday through Friday, Pacific Time excluding holidays.

Phone: 360-264-2141

Fax: 360-264-5105

Email ed@6kproducts.com

Mail and shipping address:

6K Products
1006 143rd Ave. S.E.
Tenino, WA 98589

MAIN SUB ASSEMBLIES

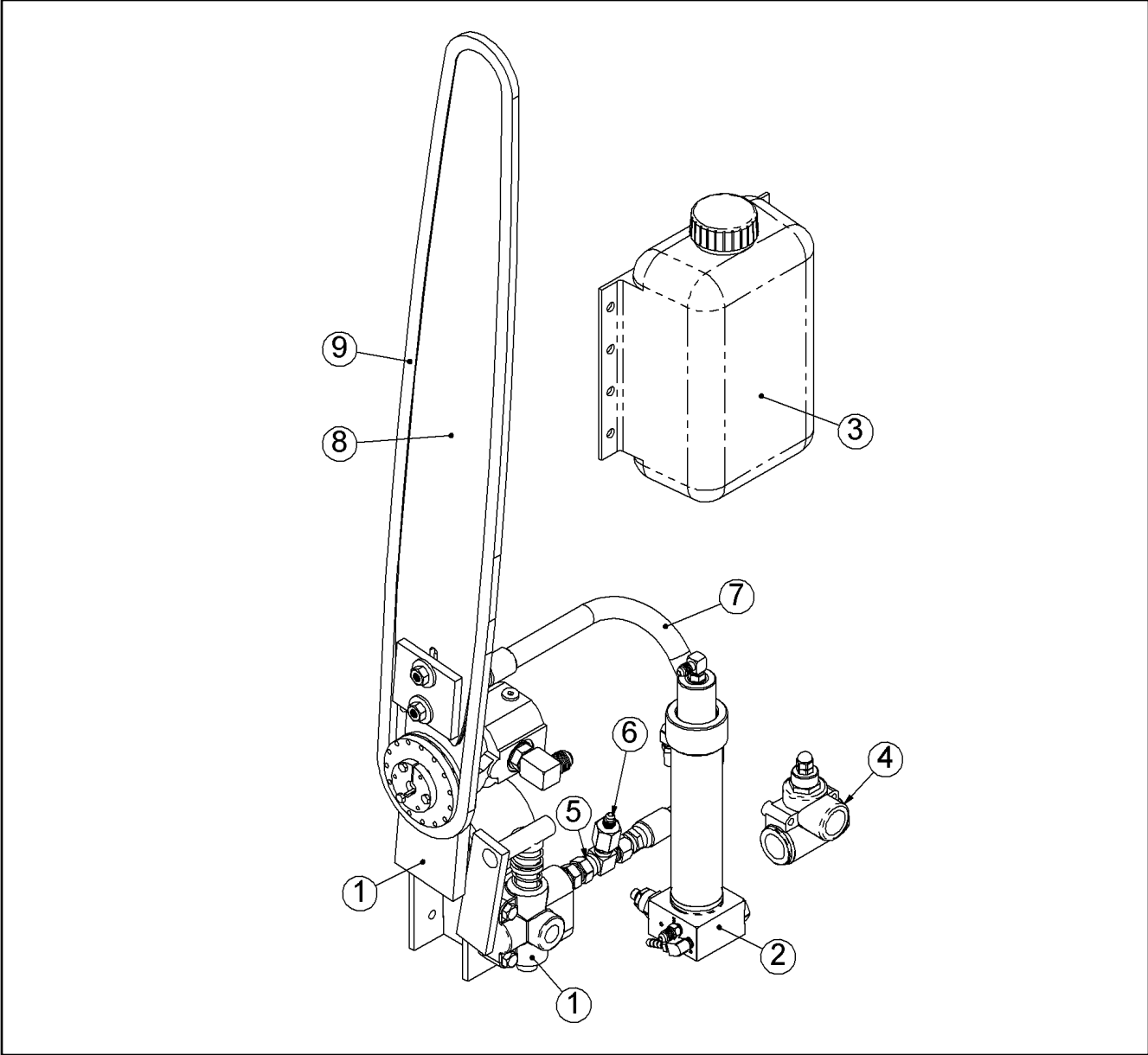

ITEM No.	QTY.	PART No.	DESCRIPTION	REMARKS
1	1	DH0617	11G SIMPLE SAW ASSEMBLY	
2	1	DH0144	BAR OIL PUMP ASSEMBLY	
3	1	DH0152	BAR OIL TANK ASSEMBLY	
4	1	VH0014	3/4 NPT 2000 PSI RELIEF VALVE	
5	1	HH0820	#8 JIC SWIVEL RUN TEE	
6	1	HH0942	TUBE REDUCER FM JIC TO M JIC, 892-6-4	
7	1	DH0143	24" #8 MOTOR HOSE ASSEMBLY	
8	1	DH0066	HARVESTER BAR, 75 CM	
9	1	DH0055	SAW CHAIN, 80 GAUGE, 89 DRIVE LINKS	

DH0617 SIMPLE SAW ASSEMBLY

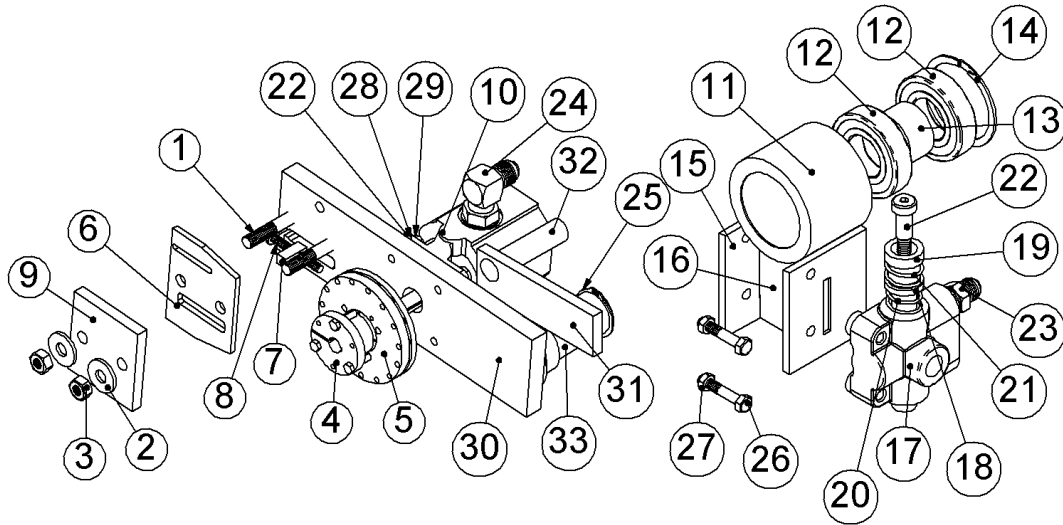

ITEM No.	QTY.	PART No.	DESCRIPTION	REMARKS
1	2	FST005	M10 X 1.5 X 52 STUD	
2	2	FMW100P	10MM REGULAR PLAIN WASHER	
3	2	FMN10CP	M10 X 1.5 NUT	
4	1	GM1000	QD-JA X 1/2 BUSHING	
5	1	DS0146	15T404TL SPROCKET	
6	1	DH0034	BAR SPACER	
7	1	DH0033	TENSION BAR	
8	1	FSM42P	1/4 -20 X 2 SS PAN HD PHILLIPS SCREW	
9	1	DH0122	CLAMP PLATE	
10	1	VMH001	HALDEX MOTOR, VENDOR NO. 10567	
11	1	DH0127	PIVOT HOUSING	
12	2	B62R07	BALL BEARING, 6207-2RS	
13	1	DH0173	BEARING SPACER	
14	1	FRI283	SPIRAL RETAINING RING, WHM-283	
15	2	DH0236	VALVE PLATE	
16	1	DH0237	SPACER PLATE	
17	1	VH0001	CROSS 20 GPM SELECTOR VALVE	
18	1	DH0239	SPRING HEAD	
19	1	DH0240	SPRING HEAD	
20	1	FXC017	1.10 OD X 1.5 X .082 WIRE	
21	1	FXC018	1.18 OD X 1.53 X .091 WIRE	
22	1	FZS18S	1/2 X 1 SOCKER SHOULDER SCREW- STRIPPER BOLT	
23	1	HH0440	MALE JIC TO PIPE ADAPTER,816-8-8	
24	2	HH0751	90° ADJUSTABLE MALE ORB TO JIC, 853-8-10	
25	1	FRS137	1.375 ø SHAFT, RETAINING RING	
26	2	F8C105	5/16 X 1 3/4 GRADE 8 NC HEX HEAD CAP SCREW	
27	2	FNC10S	5/16" NC STOVER NUT	
28	4	F8C101	5/16 X 3/4 GRADE 8 NC HEX HEAD CAP SCREW	
29	4	FWZ10H	5/16 HT WASHER	
30	1	DH0231	BAR PLATE	
31	1	DH0241	STOP BAR	
32	1	DH0242	VALVE PIN	
33	1	DH0126	PIVOT PIN	

DH0144 BAR OIL PUMP ASSEMBLY

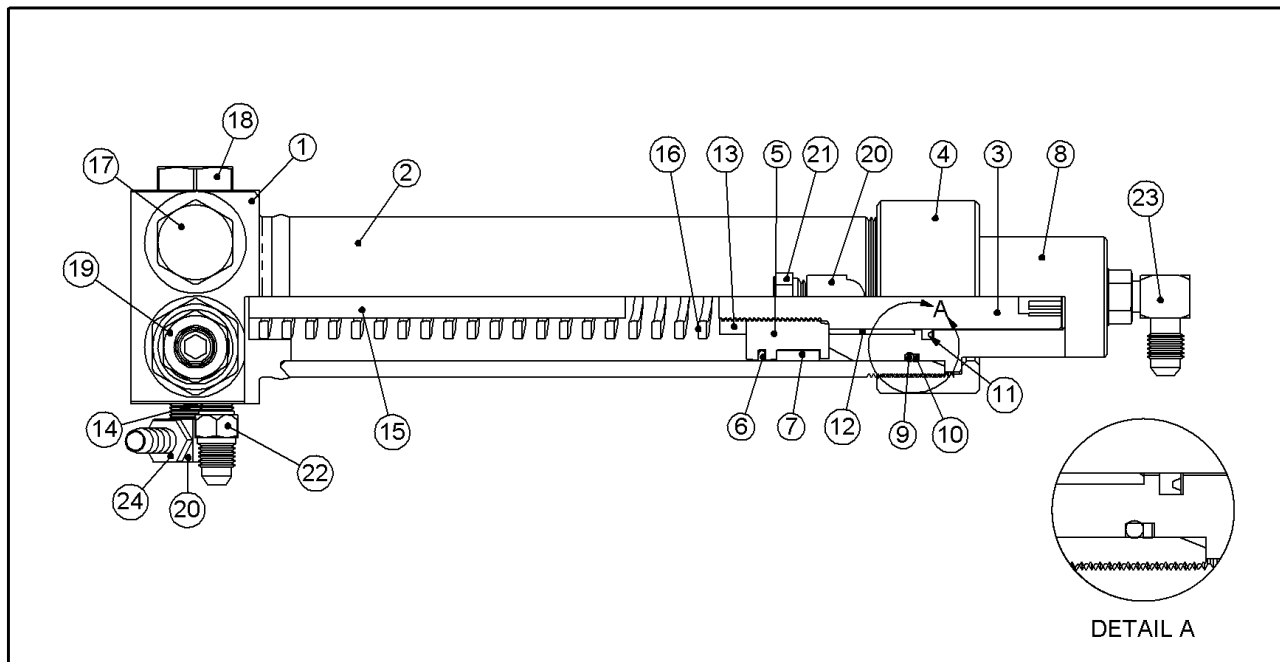

ITEM No.	QTY.	PART No.	DESCRIPTION	REMARKS
1	1	DH0147	VALVE PLATE	
2	1	DH0145	1.500" BORE CYL BARREL	
3	1	DH0146	ROD FOR DH0144	
4	1	K30121	1 1/2" BARREL NUT	
5	1	K30120	1 1/2" PISTON	
6	1	SPT026	1 1/2" TT1400 PISTON SEAL ASSY.	
7	1	SRS005	1-1/2" X 1-1/4" X 1/2" STEP CUT WEAR RING	
8	1	DH0148	PRESSURE CHAMBER	
9	1	SO2125	#2-125 O-RING	
10	1	SO8125	#8-125 BACK UP RING	
11	1	SUG011	3/4 X 1 X 1/8 U-SEAL	
12	1	BP0044	BUSHING, 3/4" X 7/8" X 1", I-GLIDE G300, GSI-1214-16	
13	1	FNF30J	9/16" NF JAM NUT	
14	1	XH0003	5/32" EXPANSION PLUG, CVES1561110A	
15	1	DH0149	SPACER	
16	1	FXC013	1 X 6 LIGHT DUTY DIE SPRING	
17	1	VHH041	CARTRIDGE VALVE, HydraForce CV08-20-0-N-25	
18	1	VHH015	CARTRIDGE VALVE, HydraForce CV08-20-0-N-04	
19	1	VHH042	CARTRIDGE VALVE, HydraForce FC10-20A	
20	2	HBP106	1/8" TO 1/8" 90° STREET ELBOW	
21	1	FGG030	1/8 NPT vent	
22	1	HH0427	MALE JIC TO PIPE ADAPTER, 816-4-2	
23	1	HH0738	90° ADJUSTABLE MALE ORB TO JIC, 853-4-4	
24	1	HB0007	HOSE END, 1/8 PIPE X 1/4 HOSE	
25	1	DH0355	BAR OIL PUMP BARREL ASSEMBLY	Items 1 and 2
26	1	DH0356	SEAL KIT	Items 6,7,9,10,11 and 12

DH0152 BAR OIL TANK ASSEMBLY

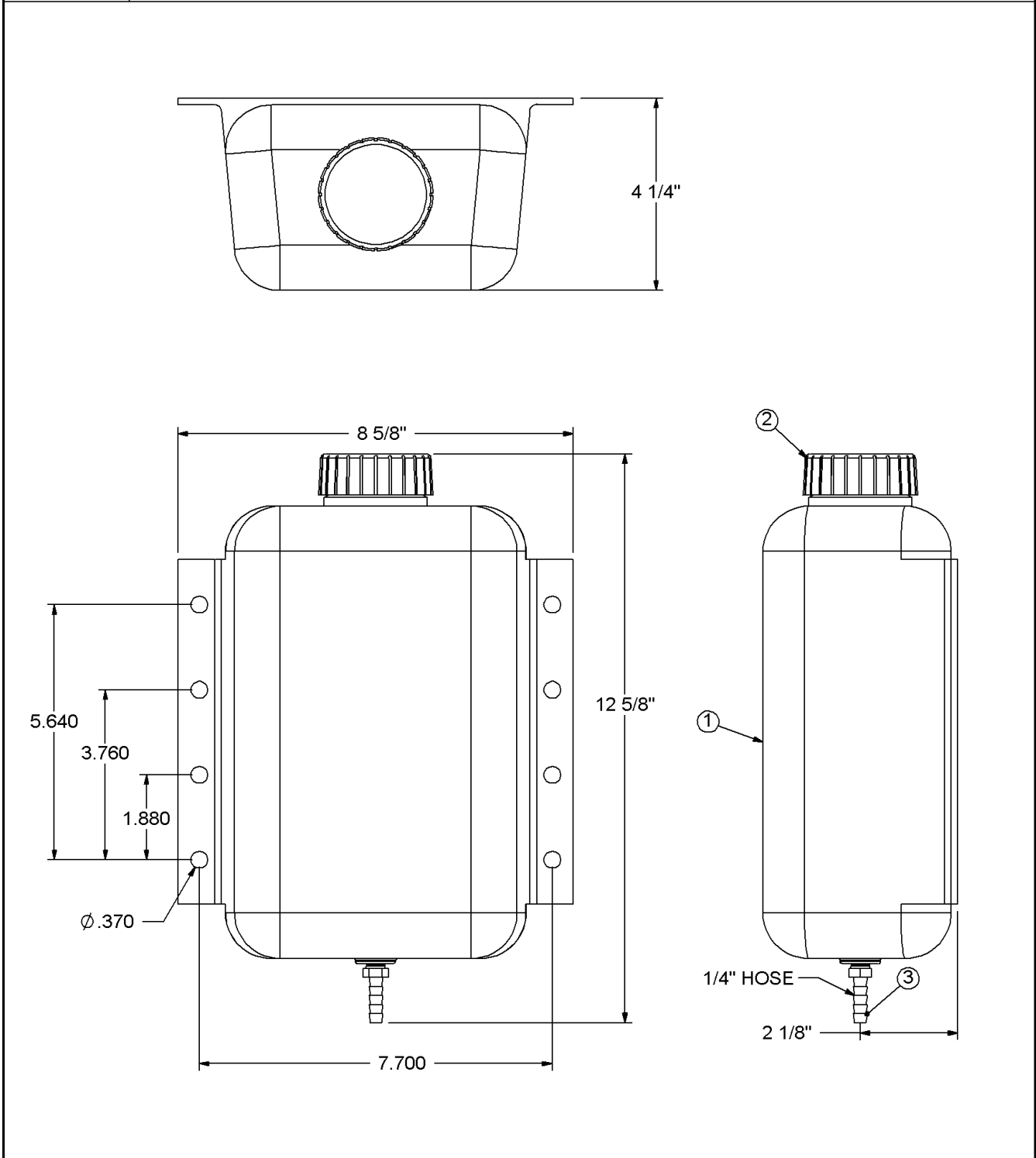

ITEM No.	QTY.	PART No.	DESCRIPTION	REMARKS
1	1	DH0150	BAR OIL TANK, 4 Quart	
2	1	DH0151	BAR OIL TANK CAP	
3	1	HB0007	HOSE END, 1/8 PIPE X 1/4 HOSE	